

V158TI MARINE ENGINE

POWER RATING

Production tolerance : $\pm 3\%$

MODEL	CONDITIONS	POWER	rpm	Base Engine
V158TIH	HEAVY DUTY	480PS (353kW)	1,800	D2848LB
V158TIM	MEDIUM DUTY	540PS (397kW)	2,100	
V158TIL	LIGHT DUTY	680PS (500kW)	2,300	

Note : 1) No reduction in rating for intake air temperature is up to 45 °C (318K) and sea water temperature is up to 32 °C (305K) , relative humidity is up to 60 % all data are based on operation to ISO 3046.

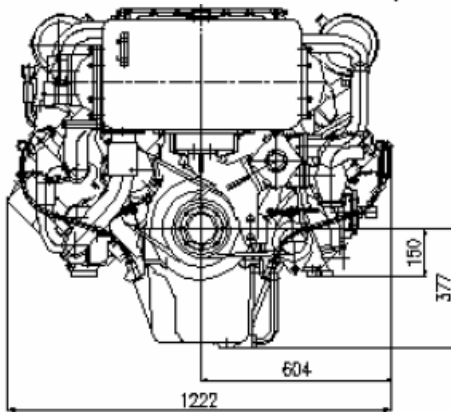

Heavy Duty

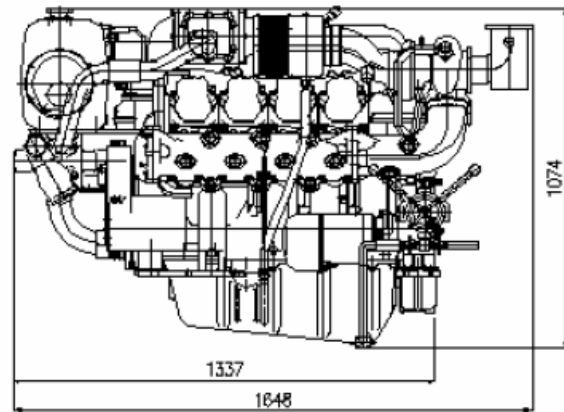

Medium Duty

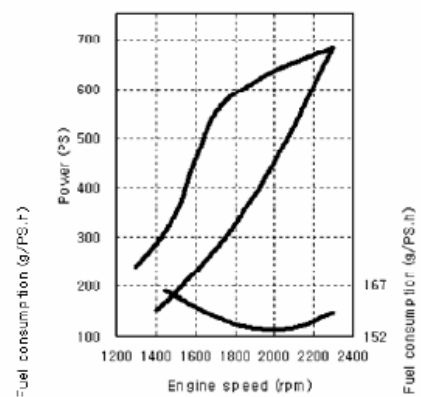
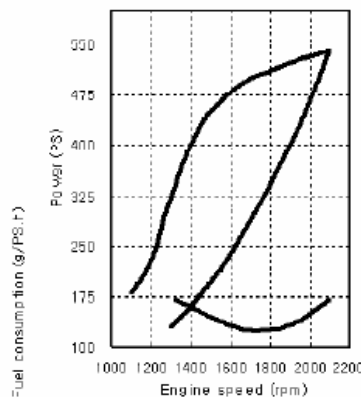
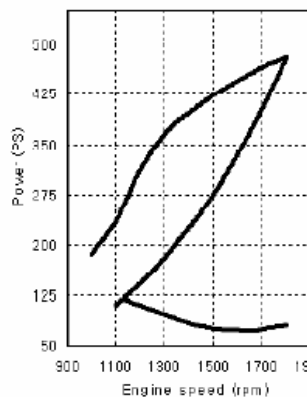

- **Heavy Duty** : Operation hours are unlimited per year, at average load is up to 90 %, at full load is up to 80 %
 Typical gearbox ratio: 2.5 ~ 6
 (Fishing trawler, Tug boat, Pushing vessel, Cargo boat, Freighter, Ferry)
- **Medium Duty** : Operation hours are up to 3,000 per year, at average load is up to 70 %
 At full load is (up to 30 % / 4hrs per 12 hour operation period).
 Typical gearbox ratio: 2 ~ 3.5
 (Fishing boat, Pilot boat, Escort boat, Passenger boat, Ferry, Cruising vessel)
- **Light Duty** : Operation hours are up to 1,000 per year, at average load is up to 50 %
 At full load is (up to 20 % / 2hrs per 12 hour operation period)
 Typical gearbox ratio: 1 ~ 2.5
 (Light weight fishing boat, Yacht, Coastguard boat, Fast boat, Fire pump, Navy, Bow thruster)

Engine Specification

Model		Units	V158TIH	V158TIM	V158TIL
Engine type			4 cycle, V type, direct- injection, water cooled with wet turbo charger & inter-cooler		
Rating output (B.H.P)		PS(kW)/rpm	480(353)/1,800	540(397)/2,100	680(500)/2,300
Displacement		cc	14,618		
Cylinder number - bore(ϕ) x stroke		mm	8 - ϕ 128 x 142		
Valve clearance at cold	In / Ex	mm	0.25 / 0.35		
Low idling rpm		rpm	725 \pm 25		
No load max. rpm		rpm	below 2,070	below 2,415	below 2,645
Mean effective pressure		kg/cm ²	16.4	15.8	18.2
Mean piston speed		m/sec.	8.52	9.94	10.89
Compression ratio			15 : 1	15:1	14.6:1
Firing order			1 - 5 - 7 - 2 - 6 - 3 - 4 - 8		
Governor type of injection pump			Mechanical variable speed (R.Q.V)		
Fuel consumption		g / PS.h	147	154	159
		Lit / h	85	100	130
Injection timing (B.T.D.C)		deg	20 \pm 1 $^\circ$	20 \pm 1 $^\circ$	20 \pm 1 $^\circ$
Starting system			Electric Starting by starter motor		
Starter motor capacity		V - kW	24 - 6.6		
Alternator capacity		V - A	24 - 50		
Battery		V - Ah	24 - 200		
Cooling system			Indirect sea water cooling with heat exchanger		
Cooling water capacity	Max. / Min.	lit.	89 / 78		
Fresh water pump type			Centrifugal type, driven by belt		
Sea water pump type			Bronze impeller type driven by belt		
Lubricating oil (Engine)	pan capacity	lit.	Max : 31, Min : 25 (Engine total : 35)		
	pressure	kg/cm ²	Full : 3.5, Idle : 1.2		
Direction of revolution	crankshaft		Counter clockwise viewed from stern side		
Engine Size (L x W x H)		mm	1,337 x 1,222 x 1,074		
Engine dry weight		kg	1,350	1,350	1,435

psi = kg/cm² x 14.22
 lb/ft. = N.m x 0.737
 kW = 0.2388 kcal/s

lb= kg x 2.205
 lb/PS.h = g/kW.h x 0.00162
 cfm = m³/min x 35.3

hp = PS x 0.98635
 U.S gal. = liter x 0.264