

# PU180TI P-DRIVE

## ◎ POWER RATING

Intermittent rating kW(PS) / rpm	Max. torque N.m(kg.m) / rpm	Fuel consumption g/kW.h(g/PS.h) / rpm
478 (650) / 2100	2303 (235) / 1500	226 (166) / 2100

- Note :
1. The engine performance corresponds to ISO 3046, DIN 6270B.
  2. Continuous duty at charge and constant speed consider on engine choice, a power derating of about 9%.
  3. Max. rpm of Continuous duty is 1,800rpm.



## ◎ MECHANICAL SYSTEM

- Engine Model PU180TI
- Engine Type V-type 4 cycle, water cooled  
Turbo charged & intercooled
- Combustion type Direct injection
- Cylinder Type Replaceable wet liner
- Number of cylinders 10
- Bore x stroke 128(5.04) x 142(5.59) mm(in.)
- Displacement 18.273(1,115.02) lit.(in<sup>3</sup>)
- Compression ratio 15 : 1
- Firing order 1-6-5-10-2-7-8-3-4-9
- Injection timing 18° BTDC
- Dry weight Approx. 1,175 kg (2,590 lb)
- Dimension 1,557 x 1,389 x 1,248 mm  
(LxWxH) (61.3 x 54.7 x 49.1 in.)
- Rotation Counter clockwise viewed from Flywheel

## ◎ MECHANISM

- Type Over head valve
- Number of valve Intake 1, exhaust 1 per cylinder
- Valve lashes at cold Intake 0.25mm (0.0098 in.)  
Exhaust 0.35mm (0.0138 in.)

## ◎ VALVE TIMING

- |                 | Opening      | Close        |
|-----------------|--------------|--------------|
| ○ Intake valve  | 24 deg. BTDC | 36 deg. ABDC |
| ○ Exhaust valve | 63 deg. BBDC | 27 deg. ATDC |

## ◎ OPTION & ACCESSORY PARTS

- Engine parts Fly wheel & housing  
Intake & exhaust manifold
- Accessory parts Raditor, silencer & air cleaner
- Electrical parts Gauge panel & stop solenoid

## ◎ FUEL SYSTEM

- Injection pump Bosch in-line "P" type
- Governor Mechanical type
- Feed pump Mechanical type
- Injection nozzle Multi hole type
- Fuel filter Full flow, cartridge type
- Used fuel Diesel fuel oil

## ◎ LUBRICATION SYSTEM

- Lub. Method Fully forced pressure feed type
- Oil pump Gear type driven by crankshaft
- Oil filter Full flow, cartridge type
- Oil pan capacity High level 35 liters ( 9.2 gal.)  
Low level 28 liters ( 7.4 gal.)
- Angularity limit Front down 24 deg.  
Front up 20 deg.  
Side to side 15 deg.
- Lub. Oil Refer to Operation Manual

## ◎ PERFORMANCE CURVE

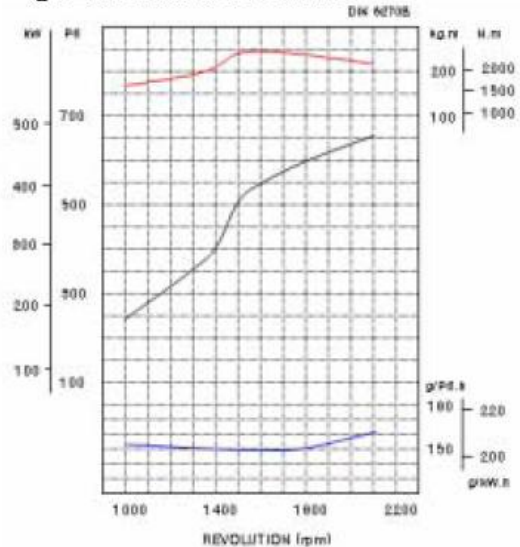

**◎ COOLING SYSTEM**

- Cooling method Fresh water forced circulation
- Water capacity 21 liters ( 5.54 gal.)  
(engine only)
- Pressure system Max. 0.5 kg/cm<sup>2</sup> ( 7.1 psi)
- Water pump Centrifugal type driven by belt
- Water pump Capacity 454 liters ( 120 gal.)/min  
at 2,100 rpm (engine)
- Thermostat Wax – pellet type  
Opening temp. 79°C  
Full open temp. 94°C
- Cooling fan Blower type, plastic  
915 mm diameter, 7 blade

**◎ ELECTRICAL SYSTEM**

- Charging generator 24V x 45A alternator
- Voltage regulator Built-in type IC regulator
- Starting motor 24V x 7.0kW
- Battery Voltage 24V
- Battery Capacity 200 AH (recommended)
- Starting aid (Option) Block heater

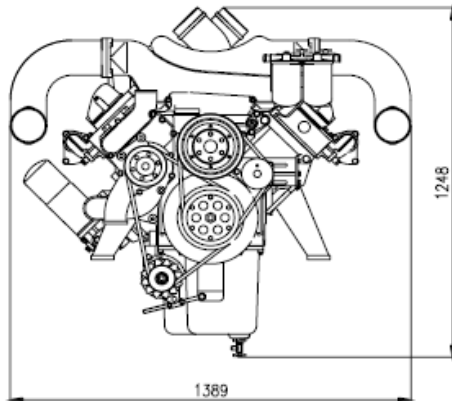

**◎ ENGINEERING DATA**

- Water flow 454 liters/min @2,100 rpm
- Heat rejection to coolant 54.4 kcal/sec @2,100 rpm
- Heat rejection to CAC 22.7 kcal/sec @2,100 rpm
- Air flow 38.0 m<sup>3</sup>/min @2,100 rpm
- Exhaust gas flow 107 m<sup>3</sup>/min @2,100 rpm
- Exhaust gas temp. 600 °C @2,100 rpm
- Max. permissible restrictions
  - Intake system 220 mmH<sub>2</sub>O initial  
635 mmH<sub>2</sub>O final
  - Exhaust system 600 mmH<sub>2</sub>O max.

**◆ CONVERSION TABLE**

- in. = mm x 0.0394      lb/ft = N.m x 0.737
- PS = kW x 1.3596      U.S. gal = lit. x 0.264
- psi = kg/cm<sup>2</sup> x 14.2233      kW = 0.2388 kcal/s
- m<sup>3</sup> = lit. x 61.02      lb/PS.h = g/kW.h x 0.00162
- hp = PS x 0.98635      cfm = m<sup>3</sup>/min x 35.336
- lb = kg x 2.20462

