

P158FE G-DRIVE

◎ POWER RATING

Engine Speed rev/min	Type of Operation	Engine Power	
		kWm	Ps
1800	Prime Power	441	600
	Standby Power	492	669
1500	Prime Power	402	546
	Standby Power	441	600

Note : -. The engine performance corresponds to ISO 3046, BS 5514 and DIN 6271.

-. Ratings are based on ISO 8528.

→ Prime power available at variable load. The permissible average power out put (during 24h period) shall not exceed 70% of the prime power rating.

→ Standby power should be applied only to provide a basic support function to a building electrical supply in the event of a main power network failure. No overload is permitted.

-. This Rating fulfills EPA exhaust emission regulation Tier-2

◎ MECHANICAL SYSTEM

○ Engine Model	P158FE
○ Engine Type	V-type 4 cycle, water cooled Turbo charged & intercooled (air to air)
○ Combustion type	Direct injection
○ Cylinder Type	Replaceable wet liner
○ Number of cylinders	8
○ Bore x stroke	128(5.04) x 142(5.59) mm(in.)
○ Displacement	14.618 (892.0) lit.(in ³)
○ Compression ratio	14.2 : 1
○ Firing order	1-5-7-2-6-3-4-8
○ Injection timing	12° BTDC (60Hz) / 10° BTDC (50Hz)
○ Compression pressure	Above 28 kg/cm ² (398 psi) at 200rpm
○ Dry weight	Approx. 997 kg (2,198 lb)
○ Dimension (LxWxH)	1,492 x 1,389 x 1,240 mm (58.7 x 54.7 x 48.8 in.)
○ Rotation	Counter clockwise viewed from Flywheel
○ Fly wheel housing	SAE NO.1
○ Fly wheel	Clutch NO.14

◎ MECHANISM

○ Type	Over head valve
○ Number of valve	Intake 2, exhaust 2 per cylinder
○ Valve lashes at cold	Intake 0.35mm (0.0138 in.) Exhaust 0.45mm (0.0177 in.)

◎ VALVE TIMING

	Opening	Close
○ Intake valve	24 deg. BTDC	30 deg. ABDC
○ Exhaust valve	59 deg. BBDC	21 deg. ATDC

◎ FUEL CONSUMPTION

○ Prime Power (lit/hr)	1,500 rpm	1,800 rpm
25%	26.5	30.7
50%	51.1	57.5
75%	77.1	85.8
100%	105.1	119.3
○ Standby Power (lit/h)	1,500 rpm	1,800 rpm
25%	29.0	34.1
50%	56.0	63.4
75%	85.1	96.7
100%	116.4	136.4

◎ FUEL SYSTEM

○ Injection pump	Bosch in-line "P" type
○ Governor	Electric type
○ Feed pump	Mechanical type
○ Injection nozzle	Multi hole type
○ Opening pressure	285 kg/cm ² (4,054 psi)
○ Fuel filter	Full flow, cartridge type
○ Used fuel	Diesel fuel oil

◎ LUBRICATION SYSTEM

○ Lub. Method	Fully forced pressure feed type
○ Oil pump	Gear type driven by crankshaft
○ Oil filter	Full flow, cartridge type
○ Oil pan capacity	High level 28 liters (7.40 gal.) Low level 26 liters (6.86 gal.)
○ Angularity limit	Front down 35 deg. Front up 35 deg. Side to side 35 deg.
○ Lub. Oil	Refer to Operation Manual

◎ **COOLING SYSTEM**

- Cooling method Fresh water forced circulation
- Water capacity 20 liters (5.28 gal.)
(engine only)
- Pressure system Max. 0.9 kg/cm² (12.8 psi)
- Water pump Centrifugal type driven by belt
- Water pump Capacity 410 liters (108.2 GPM)/min
at 1,800 rpm (engine only)
- Thermostat Wax – pellet type
Opening temp. 71°C
Full open temp. 85°C
- Cooling fan Blower type, plastic
915 mm diameter, 7 blade

◎ **ELECTRICAL SYSTEM**

- Charging generator 24V x 45A alternator
- Voltage regulator Built-in type IC regulator
- Starting motor 24V x 7.0kW
- Battery Voltage 24V
- Battery Capacity 200 AH (recommended)
- Starting aid (Option) Block heater

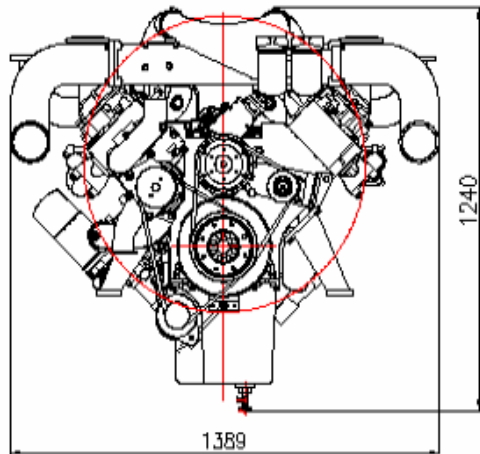

◎ **ENGINEERING DATA**

- | | |
|-----------------------------|-------------------------------------|
| ○ Water flow | 342 liters/min @1,500 rpm |
| ○ Heat rejection to coolant | 52.8 kcal/sec @1,500 rpm |
| ○ Heat rejection to CAC | 28.2 kcal/sec @1,500 rpm |
| ○ Air flow | 27.3 m ³ /min @1,500 rpm |
| ○ Exhaust gas flow | 77.1 m ³ /min @1,500 rpm |
| ○ Exhaust gas temp. | 579 °C @1,500 rpm |
-
- | | |
|-----------------------------|-------------------------------------|
| ○ Water flow | 410 liters/min @1,800 rpm |
| ○ Heat rejection to coolant | 62.9 kcal/sec @1,800 rpm |
| ○ Heat rejection to CAC | 42.2 kcal/sec @1,800 rpm |
| ○ Air flow | 33.4 m ³ /min @1,800 rpm |
| ○ Exhaust gas flow | 91.1 m ³ /min @1,800 rpm |
| ○ Exhaust gas temp. | 549 °C @1,800 rpm |
-
- Max. permissible restrictions
- Intake system 220 mmH₂O initial
635 mmH₂O final
 - Exhaust system 600 mmH₂O max.

◆ **CONVERSION TABLE**

- | | |
|------------------------------------|------------------------------------|
| in. = mm x 0.0394 | lb/ft = N.m x 0.737 |
| PS = kW x 1.3596 | U.S. gal = lit. x 0.264 |
| psi = kg/cm ² x 14.2233 | kW = 0.2388 kcal/s |
| in ³ = lit. x 61.02 | lb/PS.h = g/kW.h x 0.00162 |
| hp = PS x 0.98635 | cfm = m ³ /min x 35.336 |
| lb = kg x 2.20462 | |

